

ENGINE SPECIFICATIONS		
Configuration	Vertical in-line 3-cylinder	
Induction system	Naturally aspirated	
Combustion system	Spark-ignited	
Cooling system	Water-cooled	
Displacement	3.12 L (190 cubic inches)	
Compression ratio	9:1	
Bore x stroke	4.1 x 4.7 inches (105 x 120 mm)	
Direction of rotation	Counterclockwise	
Approx. wet weight (power unit, G-drive)	1,350 lbs., power unit	1,044 lbs., G-drive
Length (power unit, G-drive)	68.7 inches, P.U.	41.0 inches, Gdrive
Width	33.3 inches, P.U.	28.8 inches, Gdrive
Height	77.1 inches, P.U.	40.8 inches, Gdrive
Fuel type	NG/ wellhead/ LPG/ VPG	

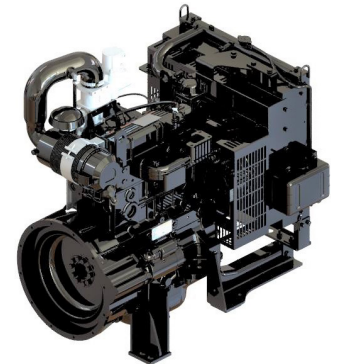
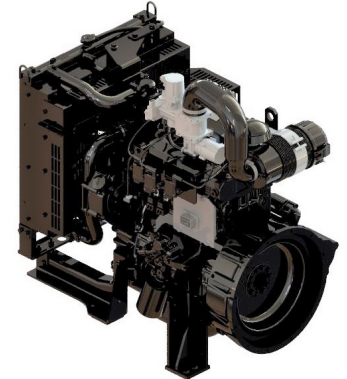

Power Ratings

50 Hz (1,500 RPM)				
Application	Fuel	kWe	kWm	bHP
Prime	NG	23	26	34
Prime	LPG/VPG	24	27	36
Standby	NG	26	28	38
Standby	LPG/VPG	27	30	40

60 Hz (1,800 RPM)				
Application	Fuel	kWe	kWm	bHP
Prime	NG	25	28	38
Prime	LPG/VPG	27	30	40
Standby	NG	28	31	42
Standby	LPG/VPG	30	33	44

Weight, physical dimensions, and power ratings are for reference only. Final product data may differ slightly.

NOTE: kWe calculated using 90 percent alternator efficiency at 0.8 power factor.

Image shown is for illustration purposes only and may not be an exact representation of the final product.

Features

- EPA-certified stationary/nonroad mobile and emergency standby
- Prime certified operating fuels – pipeline NG, LPG/VPG, and wellhead NG (700–1,600 BTU/ft³)
- Standby certified operating fuels – pipeline NG, LPG/VPG
- Single-piece cylinder head
- Stellite valves and hardened seats
- Two valves per cylinder
- Integral oil cooler with filter
- Cast-iron block
- Forged steel, dynamically balanced and counterweighted crankshaft with hardened journals
- Woodward PG+ engine control system
- Standard canbus interface (SAE J1939)
- Telematics compatible
- Bi-fuel auto switching capable

ENGINE SPECIFICATIONS	
Number of main bearings	4
Removable sleeves	Yes, standard
Ignition system	ECM, smart coil, 6+1 cam
Firing order	1-3-2
Fuel system	ECM, EFR, bi-fuel capable (NG/LPG)
AFR system	ECM, O ₂ closed loop, integral 3-way catalyst
Governor	ECM, L-Series actuator
Operating speed range	900–2,200 RPM
Electrical system	12V standard/ 24V optional
Air filter	Dry type
Oil capacity	8 quarts (7.6 L)
Oil cooler	Standard
Coolant capacity	10 quarts (9.5 L)
Fan	Suction or pusher
Flywheel	SAE 11.5
Flywheel housing	SAE 3

KP3 NA Performance Data

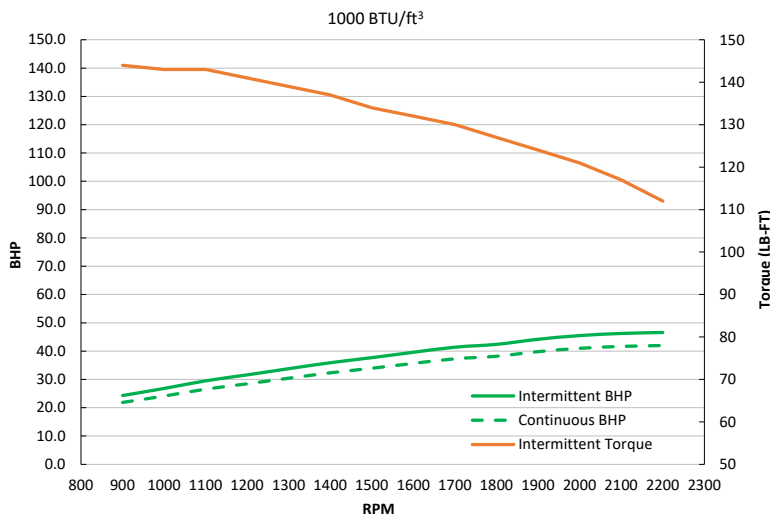

KP3 NA Fuel Economy

