



ST1000 Series Air Starters



Distributed by:



Ingersoll Rand Industrial Technologies provides products, services, and solutions that enhance our customers' energy efficiency, productivity, and operations. Our diverse and innovative products range from complete compressed air systems, tools and pumps to material and fluid handling systems and environmentally friendly microturbines. We also enhance productivity through solutions created by Club Car®, the global leader in golf and utility vehicles for businesses and individuals.

airstarters.ingersollrand.com

© 2007 Ingersoll-Rand Company IRPS-0807-041



Please Call 1-800-353-4676 for questions, pricing, or to order. We will be happy to assist you.

It all starts with Ingersoll Rand



It's a tough world out there, especially in your line of work. Between competitive market demands, bottom line concerns, and often brutal working conditions, you deal with your share of hassles. Getting — and keeping — your equipment up and running shouldn't be one of them. With an Ingersoll Rand ST1000 Series air starter, it won't be.

Ingersoll Rand has long been delivering ruggedly reliable air starters for use in the world's most demanding industries and environments. ST1000 Series air starters are our newest, most efficient starters yet — the product of more than a half-century of engineering expertise and innovation. These ultra-efficient and durable air starters deliver the power, versatility, and reliability you demand for your operation.



Power and efficiency

ST1000 Series starters consume up to 25 percent less air and gas than other models, which means you benefit from reduced operating costs and lower emissions. They provide best-in-class performance, with up to 8 percent more horsepower than competitive models and up to 18 percent more torque.

Durability

Ingersoll Rand ST1000 Series starters are ideal for harsh environments and difficult starting. Our engineers put the ST1000 Series through rigorous field and lab testing in order to ensure the starters would continue to perform without fail in any condition. A byproduct of this testing is our unique rotor design that won't clog up with particles or debris, and an integral slip clutch that eliminates shock-loading and provides better long-term protection. We use a proprietary wear-resistant coating to deliver outstanding resistance to environmental contaminations.

Brutal lab testing featuring steel shot in the starter's inlet line demonstrates the ST1000's rugged reliability



Versatility

ST1000 Series starters are available in a variety of models, with numerous inlet, exhaust, and drive housing options. With fewer parts and a convenient modular design, these starters are easier, faster, and more cost-effective to install and service.

Engineered for superior starting performance

Ingersoll Rand ST1000 Series air starters are built to withstand the toughest environmental and working conditions — combining robust features and flexibility to deliver reliable, heavy-duty starting in a wide range of industrial, oil and gas, marine, power generation, rail, and mining applications.

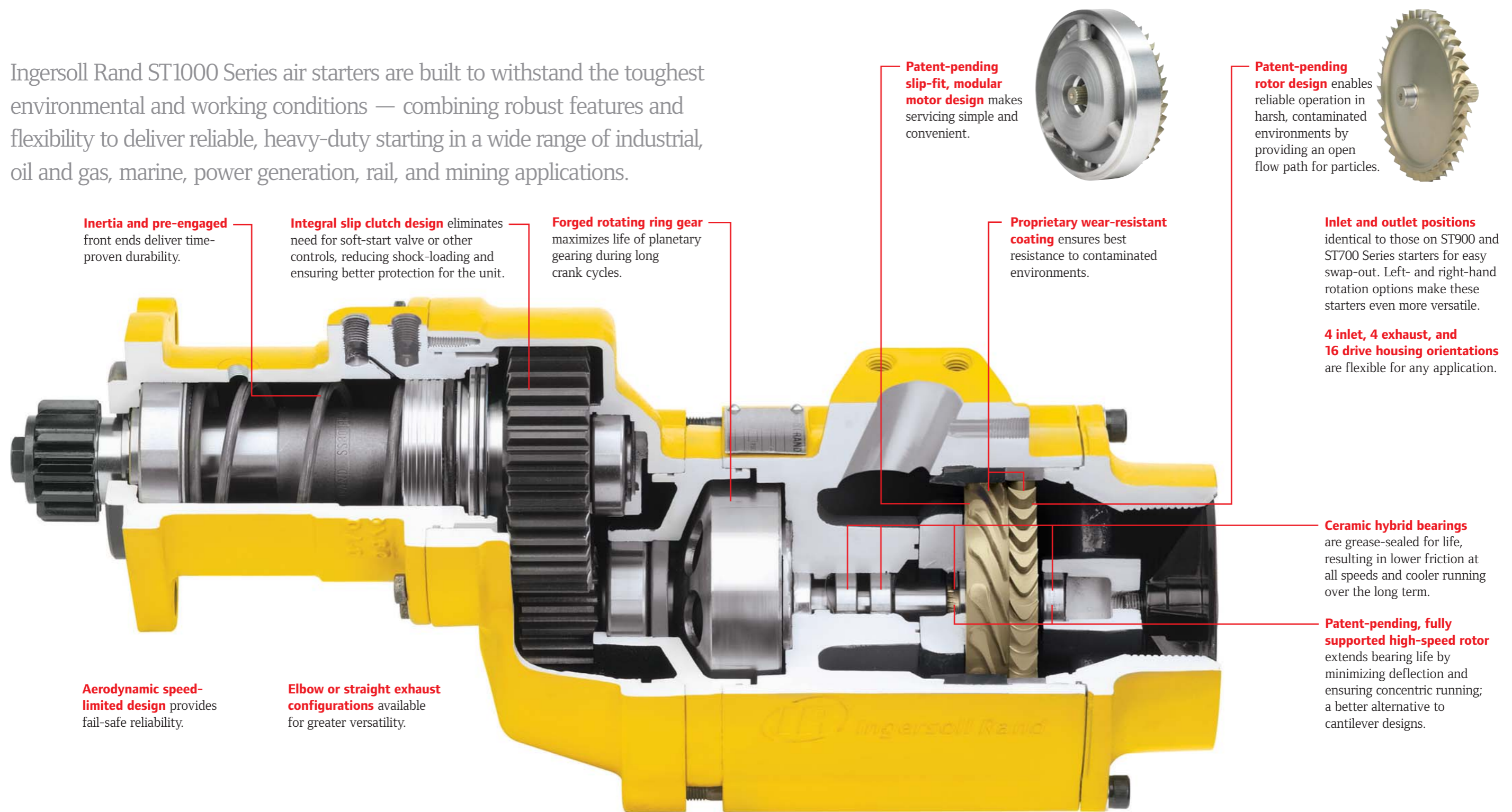

Inertia and pre-engaged front ends deliver time-proven durability.

Integral slip clutch design eliminates need for soft-start valve or other controls, reducing shock-loading and ensuring better protection for the unit.

Forged rotating ring gear maximizes life of planetary gearing during long crank cycles.

Patent-pending slip-fit, modular motor design makes servicing simple and convenient.

Proprietary wear-resistant coating ensures best resistance to contaminated environments.

Patent-pending rotor design enables reliable operation in harsh, contaminated environments by providing an open flow path for particles.

Inlet and outlet positions identical to those on ST900 and ST700 Series starters for easy swap-out. Left- and right-hand rotation options make these starters even more versatile.

4 inlet, 4 exhaust, and 16 drive housing orientations are flexible for any application.

Ceramic hybrid bearings are grease-sealed for life, resulting in lower friction at all speeds and cooler running over the long term.

Patent-pending, fully supported high-speed rotor extends bearing life by minimizing deflection and ensuring concentric running; a better alternative to cantilever designs.

Aerodynamic speed-limited design provides fail-safe reliability.

Elbow or straight exhaust configurations available for greater versatility.

No hassles, just starts

Ingersoll Rand ST1000 Series starters deliver the reliability and performance capabilities you need and can depend upon.

Engine Displacement Range		
Diesel Engines – CID (L)	1,000 – 20,000 (16 – 320)	
Carburated Engines – CID (L)	2,000 – 40,000 (32 – 660)	

Weight	
With Elbow – lb (kg)	76 (34.5)
Without Elbow – lb (kg)	69 (31.3)
D-ratio – lb (kg)	102 (46.3)

Pressure psi (bar)	Breakaway Torque ft-lb (Nm)	Speed @ Max HP rpm	Max Power hp (kW)	Flow @ Max hp scfm (L/s)
ST1060 B Ratio				
30 (2)	53 (71)	1,175	7 (5)	370 (175)
60 (4)	115 (156)	1,550	20 (15)	590 (278)
90 (6)	220 (298)	1,780	39 (29)	820 (387)
120 (8)	295 (400)	1,900	53 (39)	1,050 (496)
150 (10)	353 (478)	2,050	70 (52)	1,290 (609)
ST1099 B Ratio				
30 (2)	82 (111)	1,425	13 (10)	540 (255)
60 (4)	200 (271)	1,850	36 (27)	890 (420)
90 (6)	347 (470)	2,060	68 (51)	1,240 (585)
ST1060 C Ratio				
30 (2)	62 (84)	1,025	7 (5)	370 (175)
60 (4)	143 (194)	1,350	20 (15)	590 (278)
90 (6)	256 (347)	1,515	39 (29)	820 (387)
120 (8)	342 (463)	1,675	53 (39)	1,050 (496)
150 (10)	409 (554)	1,780	70 (52)	1,290 (609)
ST1099 C Ratio				
30 (2)	98 (133)	1,225	13 (10)	540 (255)
60 (4)	234 (317)	1,580	36 (27)	890 (420)
90 (6)	400 (542)	1,770	68 (51)	1,240 (585)
ST1060 D Ratio				
30 (2)	85 (115)	765	7 (5)	370 (175)
60 (4)	195 (264)	985	20 (15)	590 (278)
90 (6)	326 (442)	1,125	39 (29)	820 (387)
120 (8)	462 (626)	1,205	53 (39)	1,050 (496)
150 (10)	557 (755)	1,650	70 (52)	1,290 (609)
ST1099 D Ratio				
30 (2)	132 (179)	900	13 (10)	540 (255)
60 (4)	318 (431)	1,170	36 (27)	890 (420)
90 (6)	540 (732)	1,300	68 (51)	1,240 (585)

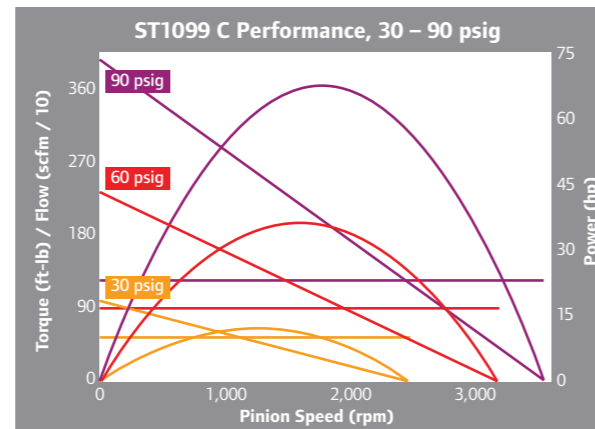
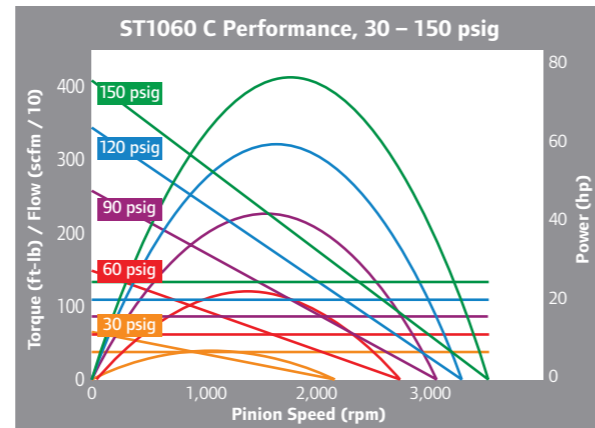
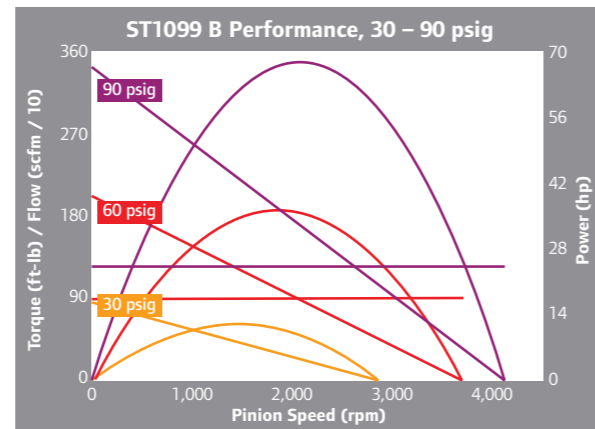
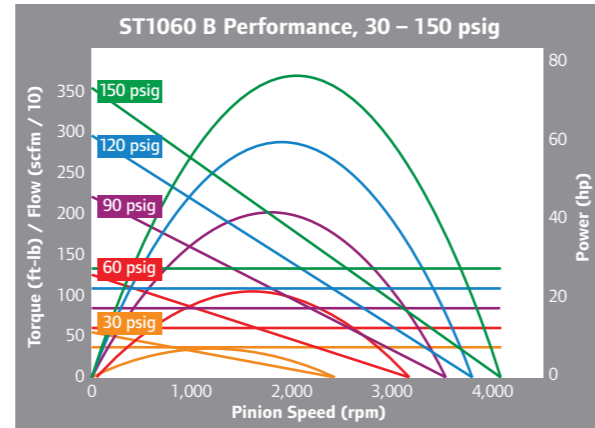

ST1000 Dimensions

Pre-Engaged B & C Ratio

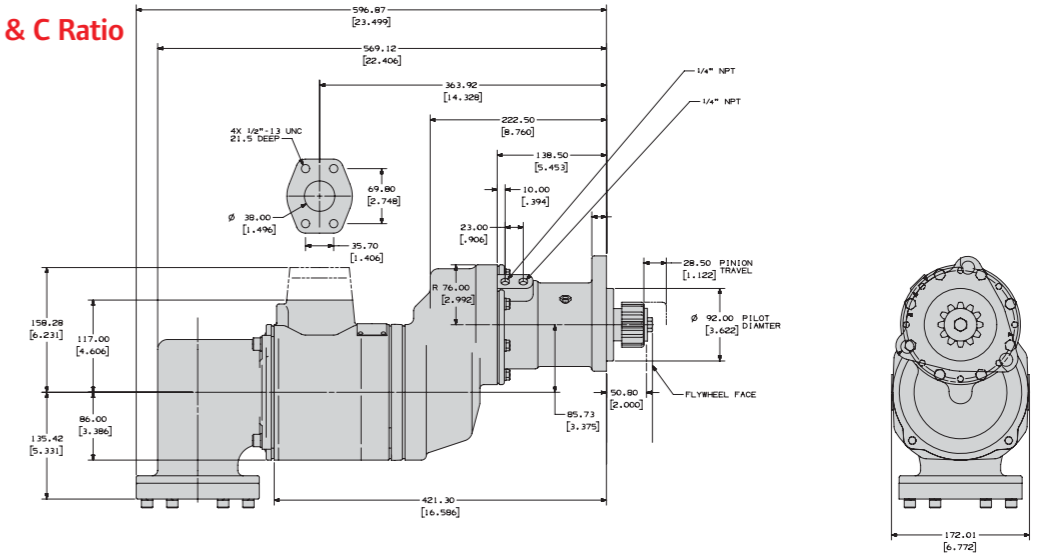

Inertia B Ratio

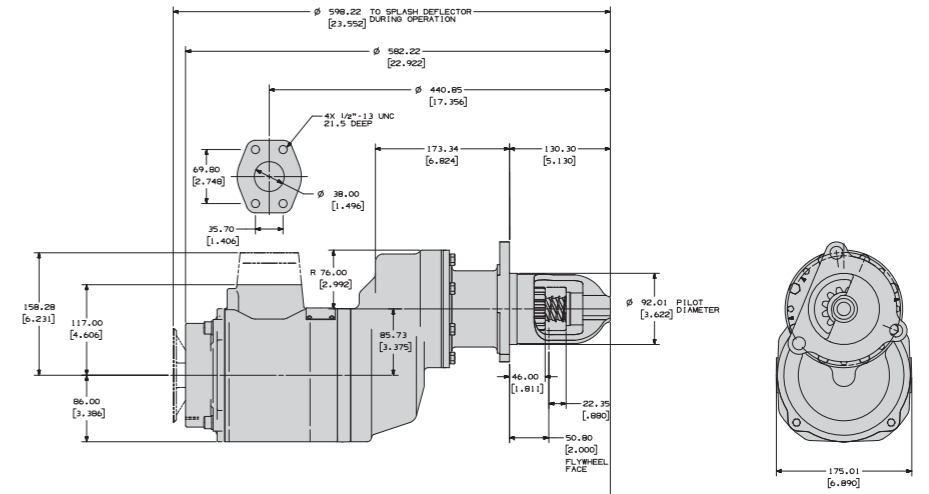

Pre-Engaged D Ratio

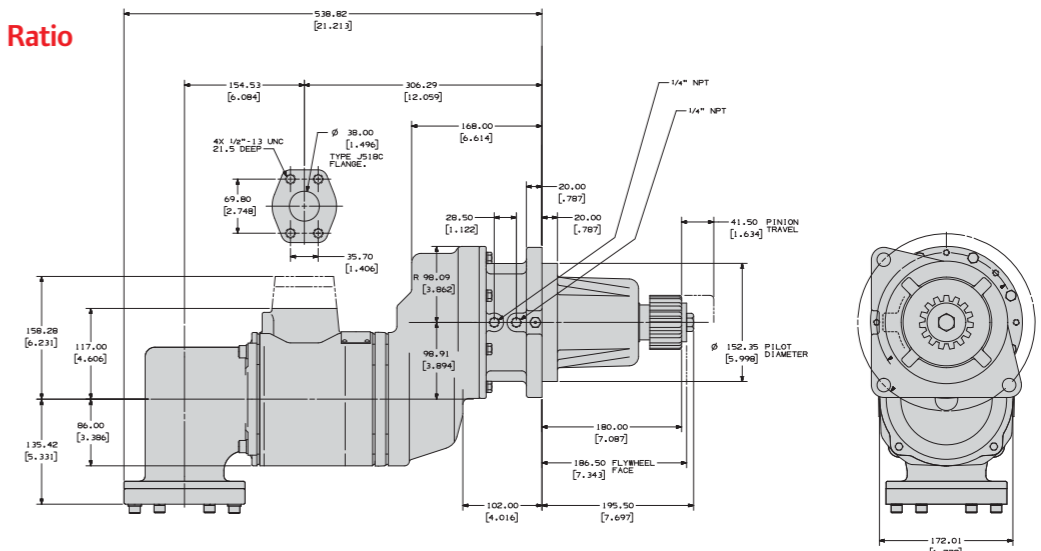

Note: Illustrations not to scale. Dimensions in mm (in). Elbow exhaust shown for pre-engaged models, but straight exhaust is also available. Elbow exhaust configuration is also available for the inertia starter shown above.

A model for virtually any application

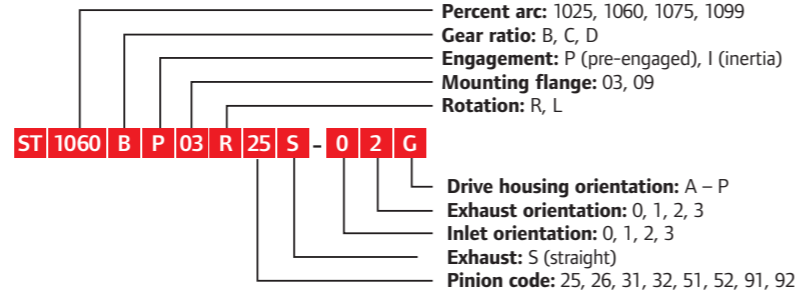

Model	Base Model	% Arc	Gear Ratio	Engagement	Mounting Flange	Rotation	Pinion	Exhaust	Inlet Orientation	Exhaust Orientation	Drive Housing Orientation
ST1060BI03L32-02G	ST1060	60%	B	Inertia	03	Left	32	Elbow	0	2	G
ST1060BI03L32S-2G	ST1060	60%	B	Inertia	03	Left	32	Straight	2	Straight	G
ST1060BI03R31-02G	ST1060	60%	B	Inertia	03	Right	31	Elbow	0	2	G
ST1060BI03R31S-2G	ST1060	60%	B	Inertia	03	Right	31	Straight	2	Straight	G
ST1060BP03L32-02G	ST1060	60%	B	Pre-Engaged	03	Left	32	Elbow	0	2	G
ST1060BP03L32S-2G	ST1060	60%	B	Pre-Engaged	03	Left	32	Straight	2	Straight	G
ST1060BP03L92-02G	ST1060	60%	B	Pre-Engaged	03	Left	92	Elbow	0	2	G
ST1060BP03R25-02G	ST1060	60%	B	Pre-Engaged	03	Right	25	Elbow	0	2	G
ST1060BP03R25S-0G	ST1060	60%	B	Pre-Engaged	03	Right	25	Straight	0	Straight	G
ST1060BP03R25S-20	ST1060	60%	B	Pre-Engaged	03	Right	25	Straight	2	Straight	0
ST1060BP03R31-02G	ST1060	60%	B	Pre-Engaged	03	Right	31	Elbow	0	2	G
ST1060BP03R31-P0S	ST1060	60%	B	Pre-Engaged	03	Right	31	Elbow		specify orientation upon order	
ST1060BP03R31S-2G	ST1060	60%	B	Pre-Engaged	03	Right	31	Straight	2	Straight	G
ST1060CP03L26-02G	ST1060	60%	C	Pre-Engaged	03	Left	26	Elbow	0	2	G
ST1060CP03L26S-2G	ST1060	60%	C	Pre-Engaged	03	Left	26	Straight	2	Straight	G
ST1060CP03L26S-3A	ST1060	60%	C	Pre-Engaged	03	Left	26	Straight	3	Straight	A
ST1060CP03L52S-2G	ST1060	60%	C	Pre-Engaged	03	Left	52	Straight	2	Straight	G
ST1060CP03R25-02G	ST1060	60%	C	Pre-Engaged	03	Right	25	Elbow	0	2	G
ST1060CP03R25-P0S	ST1060	60%	C	Pre-Engaged	03	Right	25	Elbow		specify orientation upon order	
ST1060CP03R25S-1G	ST1060	60%	C	Pre-Engaged	03	Right	25	Straight	1	Straight	G
ST1060CP03R25S-2G	ST1060	60%	C	Pre-Engaged	03	Right	25	Straight	2	Straight	G
ST1060CP03R25S-3A	ST1060	60%	C	Pre-Engaged	03	Right	25	Straight	3	Straight	A
ST1060CP03R25S-3K	ST1060	60%	C	Pre-Engaged	03	Right	25	Straight	3	Straight	K
ST1060CP03R25S-3M	ST1060	60%	C	Pre-Engaged	03	Right	25	Straight	3	Straight	M
ST1060CP03R25S-P0S	ST1060	60%	C	Pre-Engaged	03	Right	25	Straight		specify orientation upon order	
ST1060DP09L52-02G	ST1060	60%	D	Pre-Engaged	09	Left	52	Elbow	0	2	G
ST1060DP09L52S-2A	ST1060	60%	D	Pre-Engaged	09	Left	52	Straight	2	Straight	A
ST1060DP09L52S-2G	ST1060	60%	D	Pre-Engaged	09	Left	52	Straight	2	Straight	G
ST1060DP09R51-02G	ST1060	60%	D	Pre-Engaged	09	Right	51	Elbow	0	2	G
ST1060DP09R51-P0S	ST1060	60%	D	Pre-Engaged	09	Right	51	Elbow		specify orientation upon order	
ST1060DP09R51S-2G	ST1060	60%	D	Pre-Engaged	09	Right	51	Straight	2	Straight	G
ST1099BI03L32S-2G	ST1099	99%	B	Inertia	03	Left	32	Straight	2	Straight	G
ST1099BI03R31-02G	ST1099	99%	B	Inertia	03	Right	31	Elbow	0	2	G
ST1099BI03R31S-2G	ST1099	99%	B	Inertia	03	Right	31	Straight	2	Straight	G
ST1099BP03L32-02G	ST1099	99%	B	Pre-Engaged	03	Left	32	Elbow	0	2	G
ST1099BP03L32S-2G	ST1099	99%	B	Pre-Engaged	03	Left	32	Straight	2	Straight	G
ST1099BP03R31-02G	ST1099	99%	B	Pre-Engaged	03	Right	31	Elbow	0	2	G
ST1099BP03R31S-2G	ST1099	99%	B	Pre-Engaged	03	Right	31	Straight	2	Straight	G
ST1099CP03L26-02F	ST1099	99%	C	Pre-Engaged	03	Left	26	Elbow	0	2	F
ST1099CP03L26-02G	ST1099	99%	C	Pre-Engaged	03	Left	26	Elbow	0	2	G
ST1099CP03L26-02L	ST1099	99%	C	Pre-Engaged	03	Left	26	Elbow	0	2	L
ST1099CP03L26S-2G	ST1099	99%	C	Pre-Engaged	03	Left	26	Straight	2	Straight	G
ST1099CP03L52-02G	ST1099	99%	C	Pre-Engaged	03	Left	52	Elbow	0	2	G
ST1099CP03L52S-2G	ST1099	99%	C	Pre-Engaged	03	Left	52	Straight	2	Straight	G
ST1099CP03R25-02A	ST1099	99%	C	Pre-Engaged	03	Right	25	Elbow	0	2	A
ST1099CP03R25-02G	ST1099	99%	C	Pre-Engaged	03	Right	25	Elbow	0	2	G
ST1099CP03R25-03A	ST1099	99%	C	Pre-Engaged	03	Right	25	Elbow	0	3	A
ST1099CP03R25-22A	ST1099	99%	C	Pre-Engaged	03	Right	25	Elbow	2	2	A
ST1099CP03R25S-0I	ST1099	99%	C	Pre-Engaged	03	Right	25	Straight	0	Straight	I
ST1099CP03R25S-2A	ST1099	99%	C	Pre-Engaged	03	Right	25	Straight	2	Straight	A
ST1099CP03R25S-2G	ST1099	99%	C	Pre-Engaged	03	Right	25	Straight	2	Straight	G
ST1099CP03R25S-3A	ST1099	99%	C	Pre-Engaged	03	Right	25	Straight	3	Straight	A
ST1099CP03R31-02G	ST1099	99%	C	Pre-Engaged	03	Right	31	Elbow	0	2	G
ST1099CP03R31S-2G	ST1099	99%	C	Pre-Engaged	03	Right	31	Straight	2	Straight	G
ST1099CP03R51-02D	ST1099	99%	C	Pre-Engaged	03	Right	51	Elbow	0	2	D
ST1099CP03R51-02G	ST1099	99%	C	Pre-Engaged	03	Right	51	Elbow	0	2	G
ST1099CP03R51S-2G	ST1099	99%	C	Pre-Engaged	03	Right	51	Straight	2	Straight	G
ST1099DP09L52-02G	ST1099	99%	D	Pre-Engaged	09	Left	52	Elbow	0	2	G
ST1099DP09L52S-2G	ST1099	99%	D	Pre-Engaged	09	Left	52	Straight	2	Straight	G
ST1099DP09R51-02G	ST1099	99%	D	Pre-Engaged	09	Right	51	Elbow	0	2	G
ST1099DP09R51S-2G	ST1099	99%	D	Pre-Engaged	09	Right	51	Straight	2	Straight	G

Note: Additional configurations available upon request.

Typical installations

Single Unit Installation

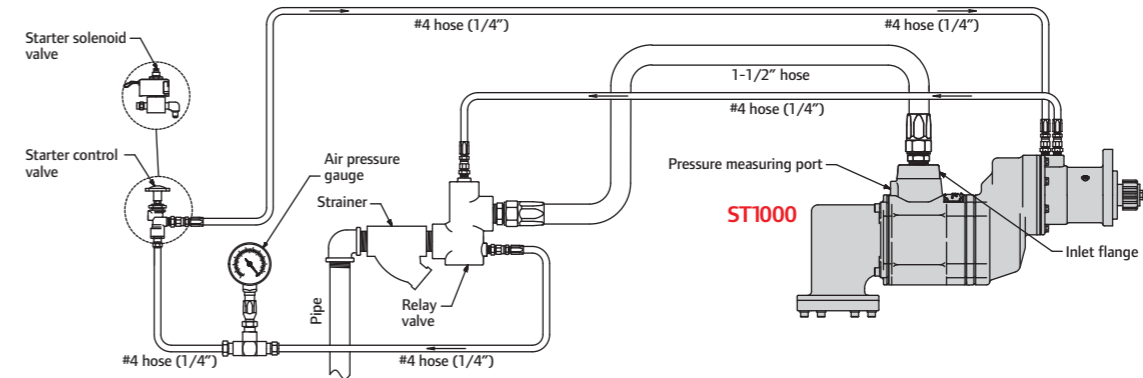

Multiple Unit Installation

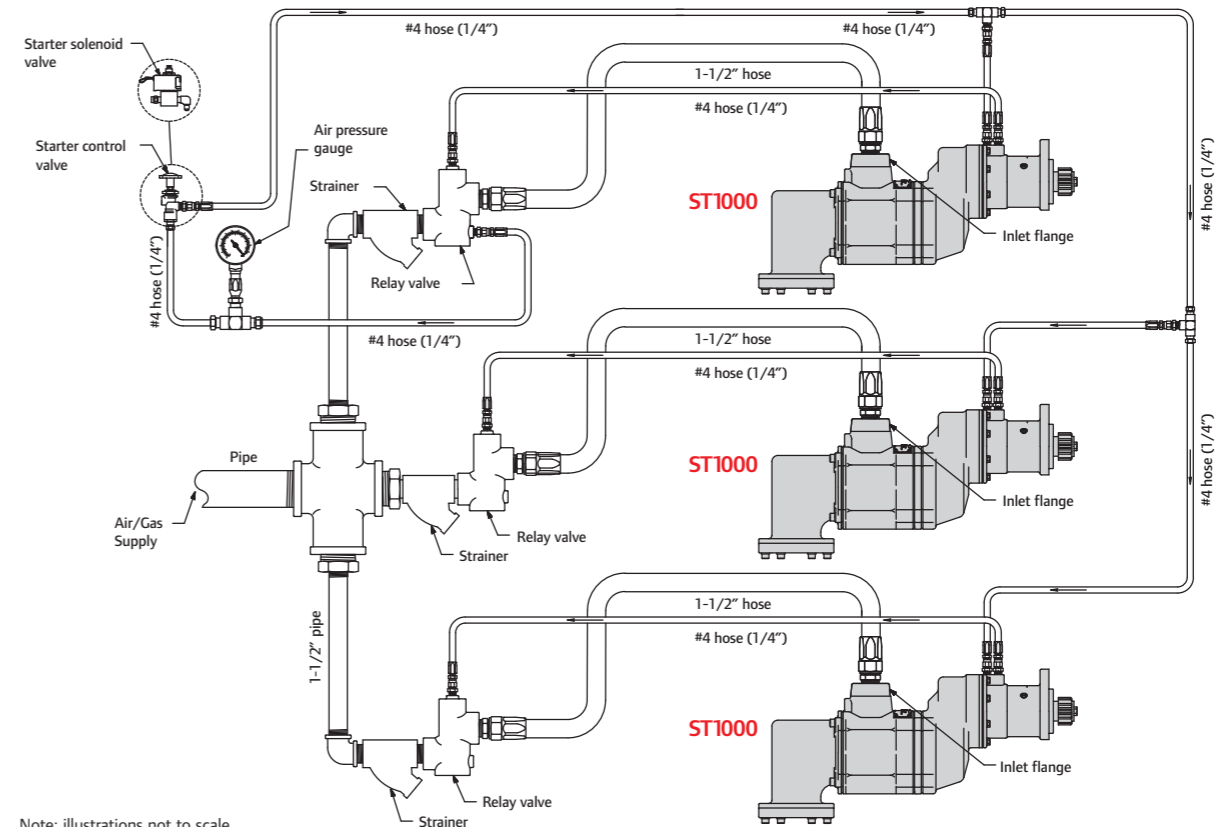











Note: illustrations not to scale.

Kits and accessories

Ingersoll Rand genuine replacement parts, kits, and accessories to support our ST1000 Series air starters.

	Part Number	Kit
	ST700P-TK7	Tune-up kit, pre-engaged
	ST700I-TK6	Tune-up kit, inertia
	ST700D-TK8	Tune-up kit, D ratio
	ST1000-SK1	Seal kit
	ST1000-GK1	Planetary gear kit
	ST1000R-K53-37	Rotor replacement kit (RH)
	ST1000L-K53-37	Rotor replacement kit (LH)
	ST1000-K24	Rotor bearing kit
	ST1000R-K212	Motor adapter kit (RH)
	ST1000L-K212	Motor adapter kit (LH)
	ST1000K-562	Straight exhaust kit
	ST1000K-350	Elbow exhaust kit
	ST700-K166	Inlet flange kit
	ST700-K167	Inlet flange hardware kit

	Part Number	Kit	
	ST1060R-37D	Motor Module (elbow exhaust)	60% Arc Motor
	ST1060L-37D	Motor Module (elbow exhaust)	60% Arc Motor
	ST1099R-37D	Motor Module (elbow exhaust)	99% Arc Motor
	ST1099L-37D	Motor Module (elbow exhaust)	99% Arc Motor
	ST1060R-37S	Motor Module (straight exhaust)	60% Arc Motor
	ST1060L-37S	Motor Module (straight exhaust)	60% Arc Motor
	ST1099R-37S	Motor Module (straight exhaust)	99% Arc Motor
	ST1099L-37S	Motor Module (straight exhaust)	99% Arc Motor
	ST1060R-37	Motor Assembly	60% Arc Motor
	ST1060L-37	Motor Assembly	60% Arc Motor
	ST1099R-37	Motor Assembly	99% Arc Motor
	ST1099L-37	Motor Assembly	99% Arc Motor
	ST700-K351	Exhaust Flange Kit	
	SRV150	1-1/2" Relay Valve For Air	
	SRV150SS	1-1/2" Gas Rated Stainless Steel Relay Valve	
	150BMP-1051B	1/4" Solenoid Valve, 12 V	
	150BMP-2451B	1/4" Solenoid Valve, 24 V	
	SMB-618	Push Button Valve	
	SMB-G618	Push Button Valve for Natural Gas Applications	
	38600714 (RR152-F30)	High Pressure Regulator Relay Valve	1.5" 90 Degree
	38754917 (RR152-F30-14)	High Pressure Regulator Relay Valve	1.5" In-line
	16675845 (RR250-F30)	High Pressure Regulator Relay Valve	2.5" In-line

Note: Max inlet pressure 450 psi

Stainless Steel Y strainer offers:

- Corrosion resistance to withstand harsh environments
- Lighter weight versus cast iron
- A rugged and compact design for simple integration
- 450 psi max working pressure
- Includes a 40 mesh stainless steel element that is durable and prevents the entry of large foreign particles



Part Number	Kit
ST1000-267-24	1-1/2" Stainless Steel Y Strainer
ST1000-266-24	1-1/2" Element (40 mesh)
ST1000-267-32	2" Stainless Steel Y Strainer
ST1000-266-32	2" Element (40 mesh)